

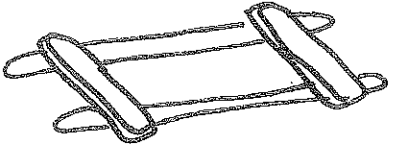
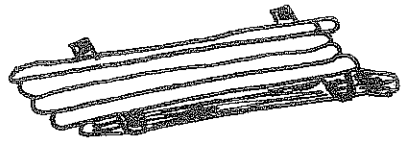
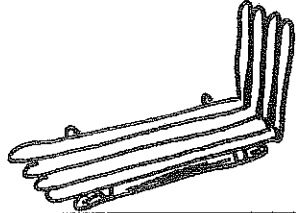
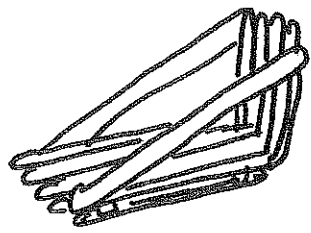
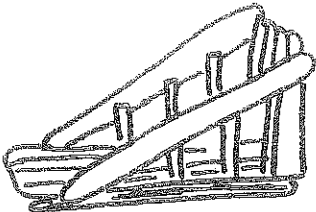

Make Your Own Dog Sled!!

Materials: 14 popsicle sticks, 6 flat wooden toothpicks, glue, 1 white pipe cleaner

	<p>Runners: Lay two popsicle sticks down for runners.</p>	
	<p>Cut two popsicle sticks in half. Lay the two halves on top of each other and glue them together.</p>	
	<p>Glue the doubled sticks on the runners, one on each end. Leave a small amount of space on each end. Let it dry.</p>	
	<p>Base of the Sled: Lay four sticks down in the exact middle of the runners as a flat base. They should line up with the back of the sled and hang over the front a bit. Glue them down. Let it dry.</p>	
	<p>Back Rest: Cut four more sticks in half. Line up five of the halves. Glue the sixth half along the bottom of the five. Glue the seventh about three-quarters of the way to the top.</p>	
	<p>Glue the back rest to the runners at the back.</p>	
	<p>Rails: Glue a popsicle stick to each side as rails along the base. The flat part should face sideways. The tops should be along the backrest, the bottoms should be next to the base. They should be slanted.</p>	

	<p>Cut the flat toothpicks in three different heights. Glue three toothpicks on each side rail. They should touch the slide rails at the top and the base at the bottom.</p>	
	<p>Cut the pipe cleaner into two pieces and arch them.</p>	
	<p>Glue one arch to the front of the base for the front of the basket. Glue the second at the top of the backrest for the handle bar.</p>	